

**63mm Strip Cap**  
**Continuous Threads**  
**Serrated with Matte Finish**

Comet Part Number: 1340-0008

**Product Benefits**

- General Purpose closure
- Ribbed sides for easy grip
- FDA approved

**Markets**

- ❖ Agricultural products
- ❖ Dressing and Sauces
- ❖ Food
- ❖ Food Services
- ❖ Industrial Applications
- ❖ Medical Products
- ❖ Cosmetics
- ❖ Pharmaceuticals

**Closure Specifications**

- Diameter: 63mm
- Thread Profile: Special
- Neck Finish: 63-SP'L
- Cap Height: 0.729 inches
- Closure Top: Matte
- Closure Sidewall: Ribbed
- Material: PP

**Options**

- Available in white, black, standard colors as well as custom colors
- Custom embossing available
- Both lined and unlined options available

**Packaging and Logistics Information**

Pack Type	Pallet Dimensions	PCS/CTN	CTNS/skid	PCS/skid	Freight
Skid	48 x 44 x 93	860	30	25,800	FOB Pitman, NJ 08071

**Location:**  
 651 Lambs Road, Pitman, NJ 08071

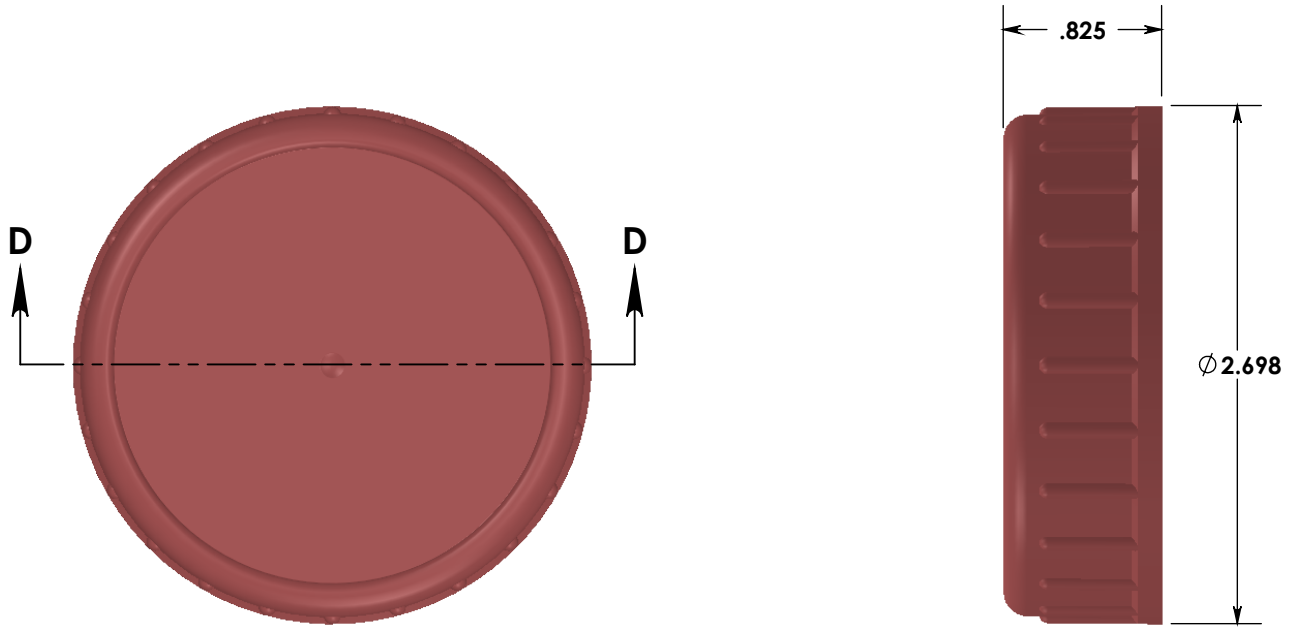

TOP SURFACE AND RIBS ARE FINISHED MATTE  
 UNSPECIFIED EXTERIOR AREAS FINISHED SPI-A3  
 UNSPECIFIED INTERIOR AREAS FINISHED SPI-B2

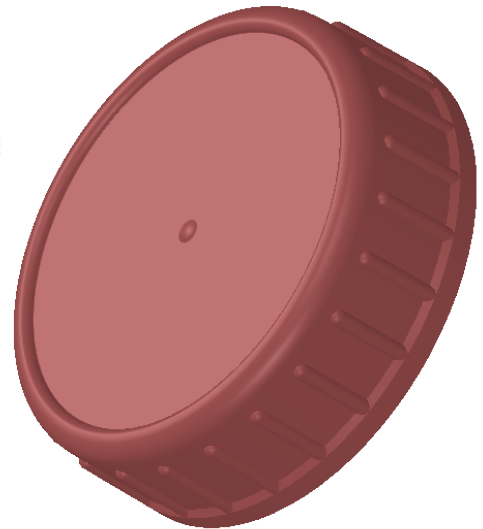
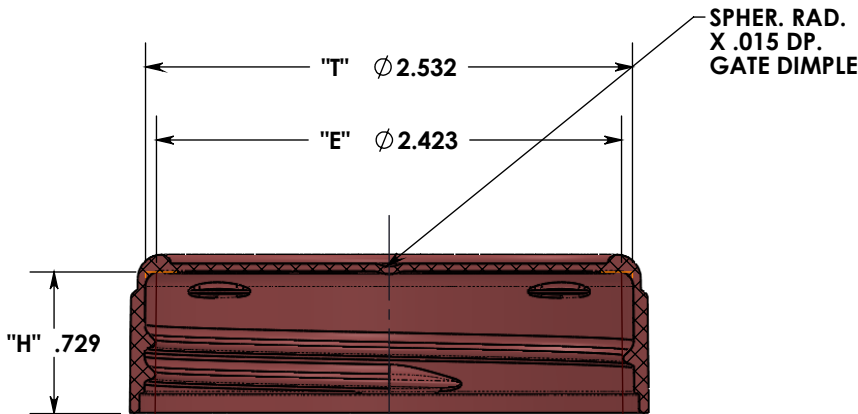

**SECTION D-D**

**ADVERTISING DRAWING  
 NOT FOR QUALITY CONTROL**

**THREAD DATA:  
 SP'L 63mm FINISH  
 .167 PITCH (6 T.P.I.)  
 1 1/4 TURNS OF THD.**

DIMENSIONS ARE IN INCHES	
TOLERANCES:	
FRACTIONAL	±1/32
ANGULAR	±1/2
TWO PLACE DECIMAL	±.03
THREE PLACE DECIMAL	±.015

PROPRIETARY AND CONFIDENTIAL	
THE INFORMATION CONTAINED IN THIS DRAWING IS THE SOLE PROPERTY OF COMET TOOL Co. ANY REPRODUCTION IN PART OR AS A WHOLE WITHOUT THE WRITTEN PERMISSION OF COMET TOOL Co. IS PROHIBITED.	
MATERIAL	
POLYPROPYLENE	
DRAWN BY	
JJM	



**COMET TOOL COMPANY**

651 LAMBS RD. PITMAN, N.J 08071-2042

TITLE:		<b>SPECIAL 63mm CT CLOSURE (OIL CAP)</b>			
PLASTIC PART NO.	PLASTIC PART REV.	DWG. NO.	SIZE	REV	DATE
1340-0008	*	1340-0008	A	*	7/21/21
SCALE: 1:1					SHEET 2 OF 2